

**SECTION A**

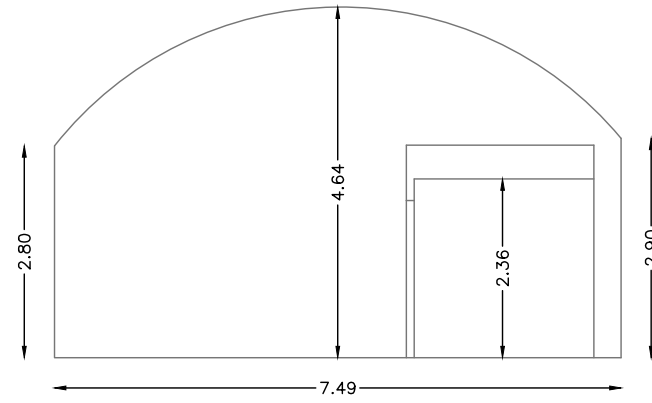

**SECTION B**

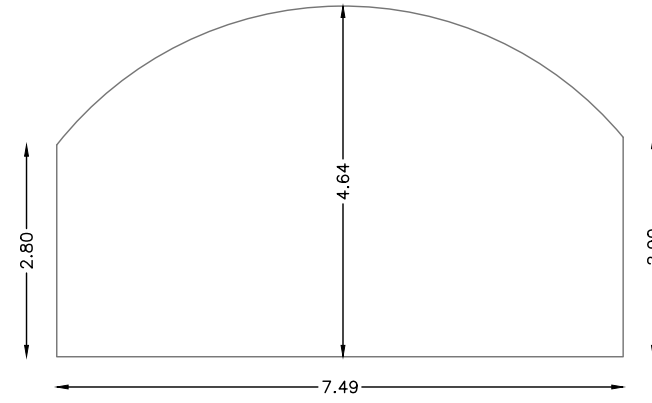

**Property Ref: WAT08500**

Arches Btn Lambeth Road And  
LONDON, SE1 7LD



**Rental Space Ref: WAT08539**

196 Carlisle Lane, LONDON, SE1

**Net Internal Area**

**NIA 148.91 sq m 1603 sq ft**

The following have been INCLUDED in the TOTAL NIA:

INT\_RAI 2.20 sq m 24 sq ft

The following have been EXCLUDED from the TOTAL NIA:

INT\_OTH 10.94 sq m 118 sq ft

**Gross Internal Area**

**GIA 159.85 sq m 1721 sq ft**

**Land Area**

**LAND 10.49 sq m 113 sq ft**

The following have been INCLUDED in the TOTAL Land Area:

EXT\_COV 10.49 sq m 113 sq ft



CARLISLE LANE

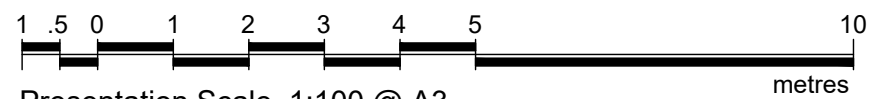
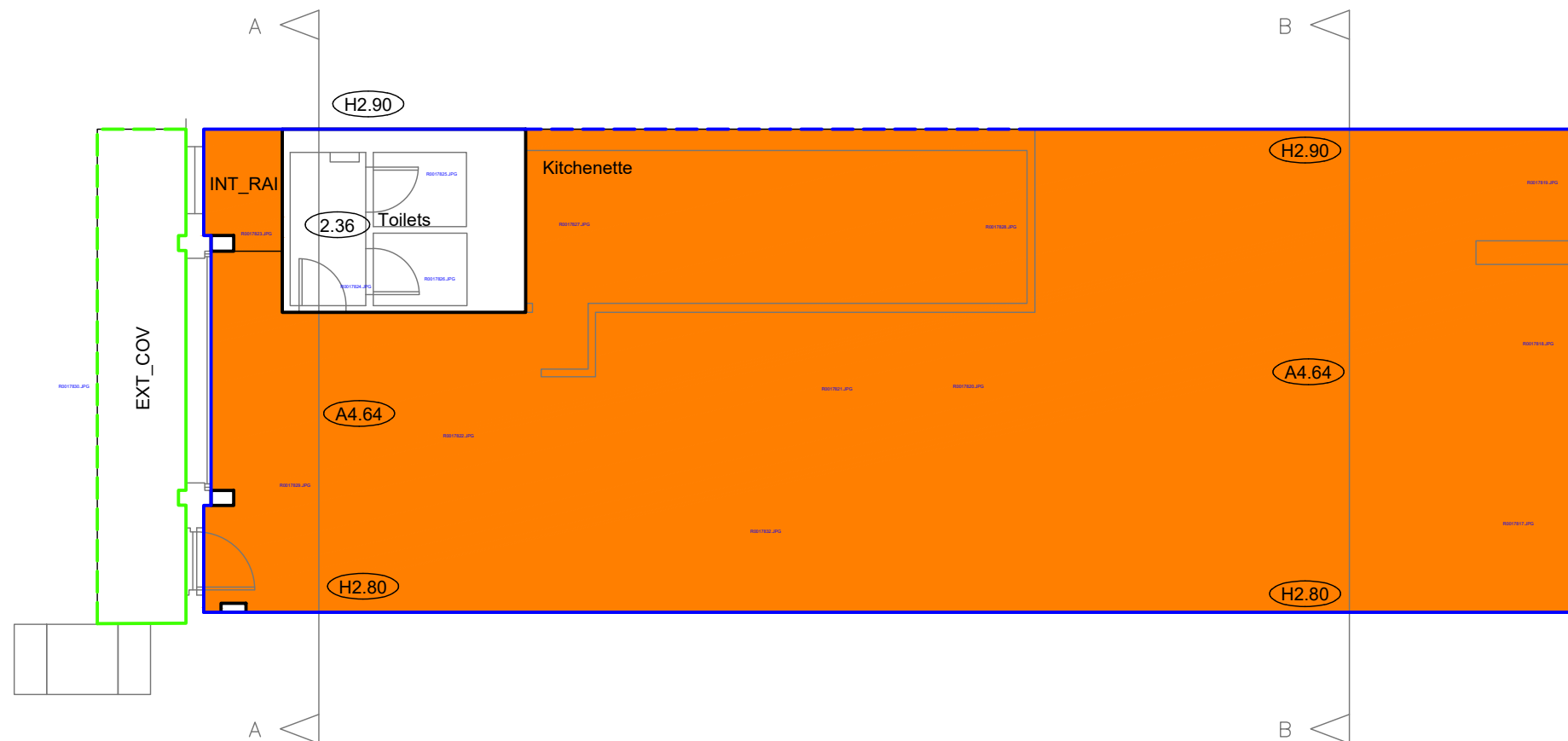

**Notes:**  
This drawing complies with the RICS Code of Measuring Practice, 6th edition (September 2007) and the Globally applicable 6th Edition (May 2015). It indicates the extent of the areas quoted, produced to an accuracy commensurate with standard presentation scales. It is held in a scaled digital CAD format. Dashed lines denote assumed wall lines inaccessible or not in situ at the time of survey.  
This drawing has been produced for area referencing purposes requested by the original commissioning agent and must not be used for any architectural or construction/engineering purposes or for any other purpose other than that for which it is originally intended. Plowman Craven Limited accepts no responsibility for details that are subsequently found to be the consequence of undisclosed facts or that were obscured from view at the time of survey or that have been altered since the date of survey.  
This drawing contains Ordnance Survey data which has been reproduced with the permission of the Controller of Her Majesty's Stationery Office, Crown copyright 2020. The Ordnance Survey data has been obtained and reproduced by Plowman Craven Ltd in agreement with The Arch Company under Network Rail Licence Number 100040692.

**Legend:**  
 (H0.00) Haunch Height (m)  
 (A0.00) Arch Maximum Height (m)  
 (0.00) Floor To Ceiling Height (m)

**Revisions:**  
 P01 - Original Issue (August 2021)

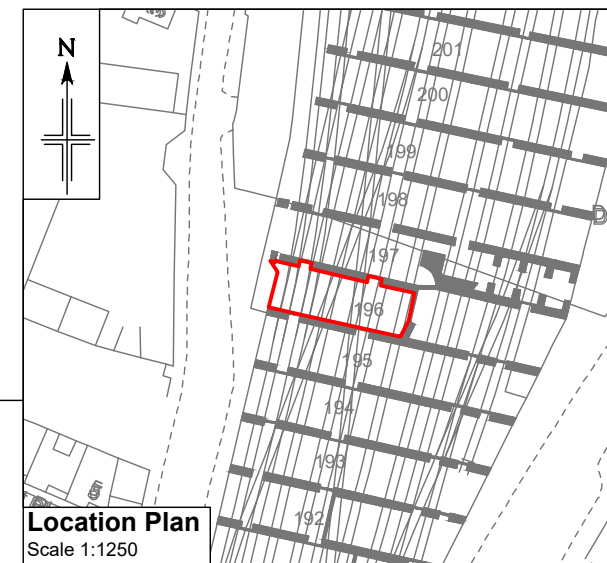

**Dwg No.**  
 43264-PCL-WAT08539-GF-DR-G-00001\_Master-S6-P01

